



KPOE-200BT

Industrial IEEE 802.3bt PSE Mid-span Injector

Installation Guide



DOC.240409A

(C) 2024 KTI Networks Inc.

All rights reserved. No part of this documentation may be reproduced in any form or by any means or used to make any derivative work (such as translation or transformation) without permission from KTI Networks Inc.

KTI Networks Inc. reserves the right to revise this documentation and to make changes in content from time to time without obligation on the part of KTI Networks Inc. to provide notification of such revision or change.

For more information, contact:

15F-7, No. 79, Sec. 1, Hsin-Tai-Wu RD

His-chih, New Taipei City, Taiwan

Fax: 886-2-26983873

E-mail: kti@ktinet.com.tw

URL: <http://www.ktinet.com.tw/>

The information contained in this document is subject to change without prior notice.

Copyright © All Rights Reserved.

TRADEMARKS

Ethernet is a registered trademark of Xerox Corp.

FCC NOTICE

This device complies with Part 15 of the FCC Rules. Operation is subject to the following two conditions: (1)

This device may not cause harmful interference, and (2) This device must accept any interference received, including the interference that may cause undesired operation.

CE NOTICE

Marking by the symbol indicates compliance of this equipment to the EMC directive of the European Community. Such marking is indicative that this equipment meets or exceeds the following technical standards:

EN 61000-6-4

EN 61000-3-2

EN 61000-3-3

EN 61000-6-2

IEC 61000-4-2

IEC 61000-4-3

IEC 61000-4-4

IEC 61000-4-5

IEC 61000-4-6

IEC 61000-4-8

IEC 61000-4-11

VCCI-A Notice

この装置は、クラスA情報技術装置です。この装置を家庭環境で使用すると電波妨害を引き起こすことがあります。この場合には使用者が適切な対策を講ずるよう要求されることがあります。

VCCI-A

Table of Contents

1. Introduction.....	5
1.1 Features	5
1.2 Product Panels.....	6
1.3 LED Indicators	6
1.4 Specifications.....	7
2. Installation.....	11
2.1 Safety Cautions.....	11
2.2 Mounting the Device to a Wall	12
2.3 Mounting the Device to a DIN-Rail.....	12
2.3 Mounting the Device on a Panel	14
2.4 Applying DC Power	16
2.4.1 Power Loss	18
3. Making LAN Connections.....	19
3.1 Data In Jack	19
3.2 PoE OUT Jack	19
3.3 Connection Distance.....	20
3.4 LED Indication.....	21
4. Supporting Products.....	22

1. Introduction



Power over Ethernet provides a way for Ethernet network devices to be powered by UTP cables, including Cat.5, 5e, and 6 rather than by separate power cords. The device is a mid-span injector that can deliver output power supporting IEEE 802.3bt Type 3 & 4 PDs, 802.3at Type 2 high-power PDs, and 802.3af Type 1 PDs. The injector supports both Fast Ethernet connection and Gigabit Ethernet connection.

For no damage to the connected device, it is enhanced with smart design to discover compliant PD. It shuts down the power immediately when incompliance is discovered. For safety, other protections for conditions such as disconnection, overload, over-current, and short circuit are also provided to secure your network installation. It is an ideal mid-span that supplies reliable, uninterrupted power up to 90W to IP phones, 802.11 access points, pan-tilt-zoom cameras, and other Ethernet devices using existing LAN cable infrastructure.

1.1 Features

- Supports both Fast Ethernet and Gigabit Ethernet
- Backward compatible with 802.3af, 802.3at and 802.3bt compliant PDs
- Delivers power output up to 90W
- Type 1 ~ Type 4 compliant PD discovery & classification
- Power shutdown protection for incompliant PD
- Power shutdown protection for disconnection
- Power shutdown protection for overload, over-current, and short circuit
- Multiple built-in power connectors to support a variety of external power supply
- Plug and play with no configuration required
- Supports DIN-rail and panel mounting

1.2 Product Panels

The following figure illustrates the components of the device:

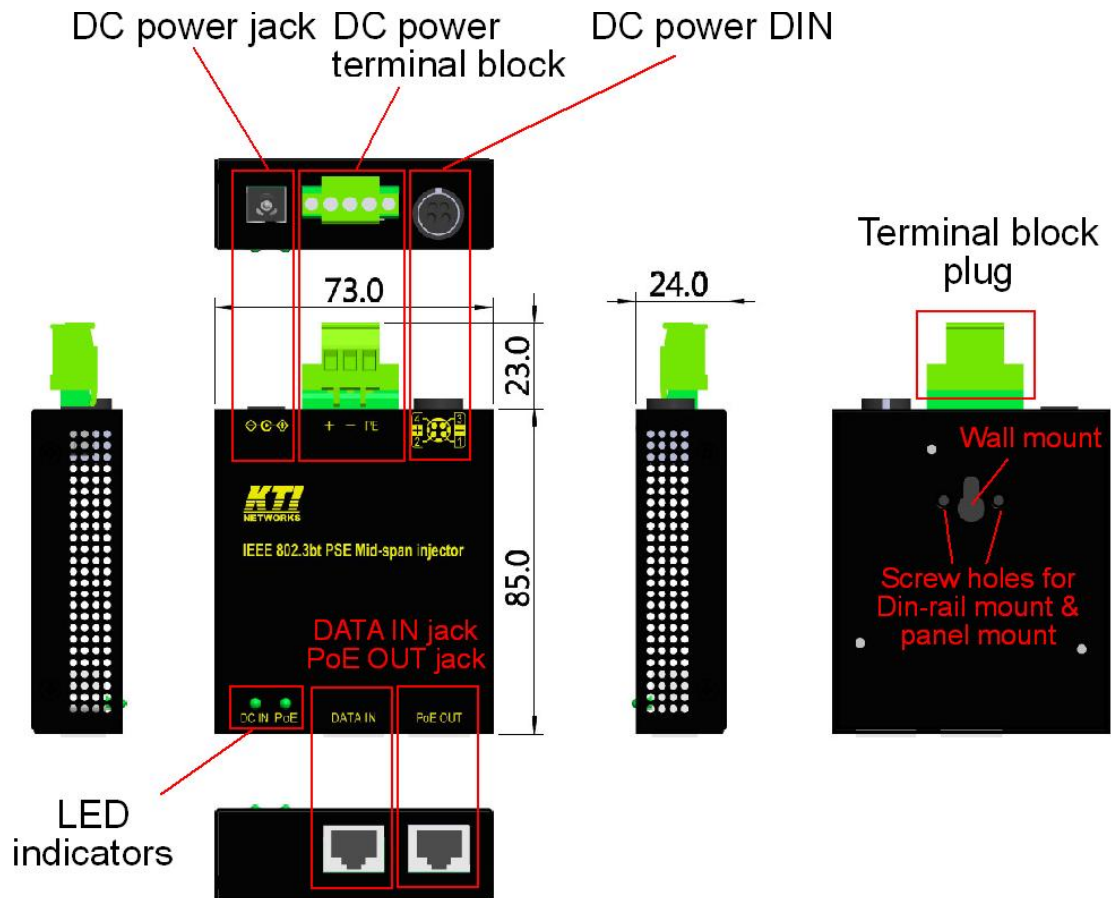

1.3 LED Indicators

<u>LED</u>	<u>Function</u>
DC IN	DC power input status
PoE	PoE output power status

1.4 Specifications

DATA IN Jack

Connector	Shielded RJ-45 jack
Connection support	IEEE 802.3 10Base-T, IEEE 802.3u 100Base-TX, IEEE 802.3ab 1000Base-T
Network cable	Cat.5, 5e, 6 UTP or better
Pin assignments	10/100Base-TX & 1000Base-T connections

Pin	10/100Base-TX	1000Base-T
1	RX+	BI_DA+
2	RX-	BI_DA-
3	TX+	BI_DB+
4		BI_DC+
5		BI_DC-
6	TX-	BI_DB-
7		BI_DD+
8		BI_DD-

PoE OUT Jack

Connector	Shielded RJ-45 jack
Connection support	IEEE 802.3 10Base-T, IEEE 802.3u 100Base-TX, IEEE 802.3ab 1000Base-T
Network cable	4-pair Cat.5, 5e, 6 UTP or better (not bundled)
PoE	PSE output, mid-span The cable distance including the segment from the injector to the Ethernet device and the segment to PD is no more than 100 meters.
Pin assignments	V_{poe} : PoE power

Pin	10/100Base-TX	1000Base-T	PoE
1	RX+	BI_DA+	V_{poe} -
2	RX-	BI_DA-	V_{poe} -
3	TX+	BI_DB+	V_{poe} +
4		BI_DC+	V_{poe} +
5		BI_DC-	V_{poe} +
6	TX-	BI_DB-	V_{poe} +
7		BI_DD+	V_{poe} -
8		BI_DD-	V_{poe} -

DC Power Terminal Block

Connector Flange terminal block 3P
Rating 57VDC, 2.1A
Contacts DC Isolated to chassis ground

Pin	Marking	Remark
1	DC+	DC power input (+)
2	DC-	DC power input (-)
3	PE	Protective earth (Connected to chassis ground inside)

DC Power Jack

Connector DC Jack (-Ø6.3mm/+Ø2.0mm) for external AC-DC power adapter
Rating 48VDC, 2.1A
Contacts Isolated to frame ground

Contact	Marking	Remark
Center (Ø2.0mm)	<+>	DC power input (+)
Outer (Ø6.3mm)	<->	DC power input (-)

DC Power DIN

Connector Female power DIN for external AC-DC power adapter
Rating 48VDC, 2.1A
Contacts Isolated to frame ground

Pins	Marking	Remark
2, 4	DC+	DC power input (+)
1, 3	DC-	DC power input (-)

DC Power

Working Voltage +55 ~ +57VDC for 45W+ high-power connection
+51 ~ +57VDC for 30W+ high-power connection
+45 ~ +57VDC for general connection

Power Over Ethernet

PoE PSE type Mid-span injector
Standard IEEE 802.3af, IEEE 802.3at, and IEEE 802.3bt
PSE power pins Pin 3/4/5/6: V_{poe+} , Pin 1/2/7/8: V_{poe-} (V_{poe} : DC power input)
Power delivery 90W max. at port output (Depending on DC power voltage)
Protection PoE output shutdown
Protection events Incompliant PD detection, PD disconnection

Overload, Over-current, Short-circuit, Under voltage

PoE PD classes support PSE output vs. PD input

Type	Class	DC power min. *1	PSE output	PD input min. *2
1	0	45V	15.4W	12.95W
1	1	45V	4W	3.84W
1	2	45V	7W	6.49W
1	3	45V	15.4W	12.95W
2	4	51V	30W	25.5W
3	5	55V	45W	40W
3	6	55V	60W	51W
4	7	55V	75W	62W
4	8	55V	90W	71W

*1: The minimum DC power voltage to support the specified PSE output

*2: The minimum power received at the PD end in worst case

Mechanical

Dimension (base)	73 x 24 x 85 mm (Case WxDxH)
Housing	Enclosed metal with no fan
Mounting	Din-rail mounting, Panel mounting (with optional bracket)

Environmental

Operating Temperature	Typical -40°C ~ +70°C (Main device)
Storage Temperature	-40°C ~ +85°C
Relative Humidity	5% ~ 95% non-condensing

Tests and Approvals

FCC Part 15 rule Class A
CE EMC Class A
VCCI V-3 Class A
EN 61000-6-4 Emission
EN 61000-3-2
EN 61000-3-3
EN 61000-6-2 Immunity for industrial environment,
IEC 61000-4-2
IEC 61000-4-3
IEC 61000-4-4

IEC 61000-4-5

IEC 61000-4-6

IEC 61000-4-8

IEC 61000-4-11

IEC 62368-1 (EN 62368-1 LVD) Safety



IEC 60068-2-64 Vibration

IEC 60068-2-27 Shock test

2. Installation

2.1 Safety Cautions

To reduce the risk of bodily injury, electrical shock, fire and damage to the product, observe the following precautions:

	Do not service any product except as explained in your system documentation.	
	Opening or removing covers may expose you to electrical shock.	
	Only a trained service technician should service components inside these compartments.	
	<p>If any of the following conditions occur, unplug the product from the electrical outlet and replace the part or contact your trained service provider:</p> <ul style="list-style-type: none"> - The power cable, extension cable, or plug is damaged. - An object has fallen into the product. - The product has been exposed to water. - The product has been dropped or damaged. - The product does not operate correctly when you follow the operating instructions. 	
	Do not push any objects into the openings of your system. Doing so can cause fire or electric shock by shorting out interior components.	
	Operate the product only from the type of external power source indicated on the electrical ratings label. If you are not sure of the type of power source required, consult your service provider or local power company.	
	 Tamb=70°C	<p>Since the product is high temperature device, install and operate the product only by authorized personnel only. Install the product at a restricted area where un-authorized persons can not reach.</p>

2.2 Mounting the Device to a Wall

The back panel of the device is featured a wall mount hole as follows:

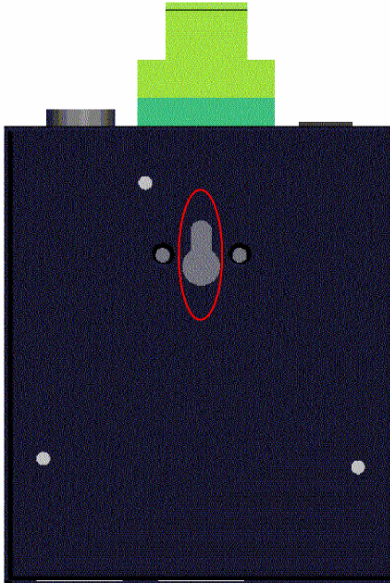

2.3 Mounting the Device to a DIN-Rail

In the product package, a DIN-rail bracket is provided or has been installed for mounting the device in a industrial DIN-rail enclosure.



The steps to mount the device onto a DIN rail are:

1. Install the mounting bracket onto the back of the device with screws as shown below:

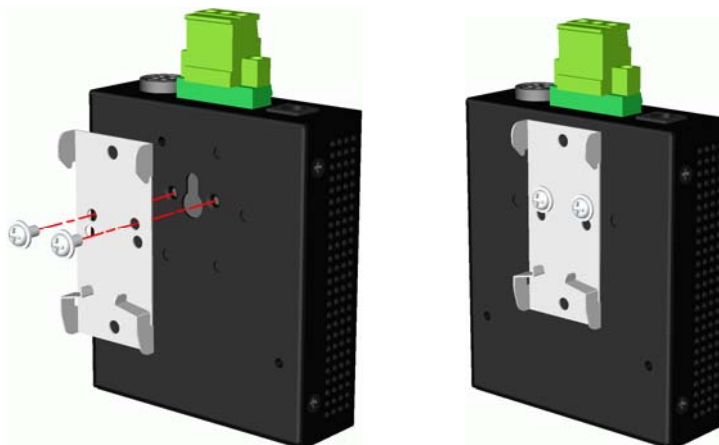

2. Attach bracket to the lower edge of the DIN rail and push the unit upward a little bit until the bracket can clamp on the upper edge of the DIN rail.
3. Clamp the unit to the DIN rail and make sure it is mounted securely.



The final dimension is:

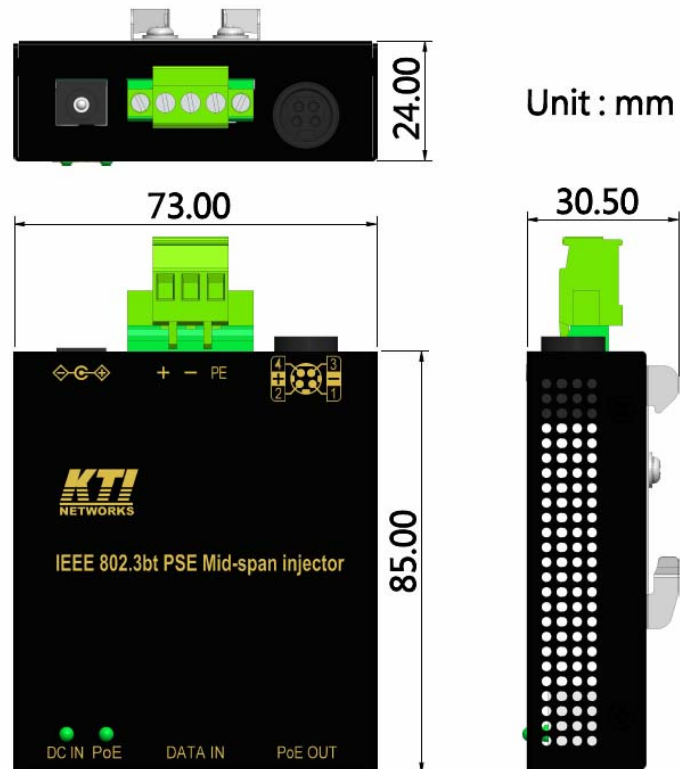

2.3 Mounting the Device on a Panel

The device may be provided optionally with a panel mounting bracket. The bracket supports mounting the device on a plane surface securely. The mounting steps are:

1. Install the mounting bracket on the device.



2. Screw the bracket on the device.

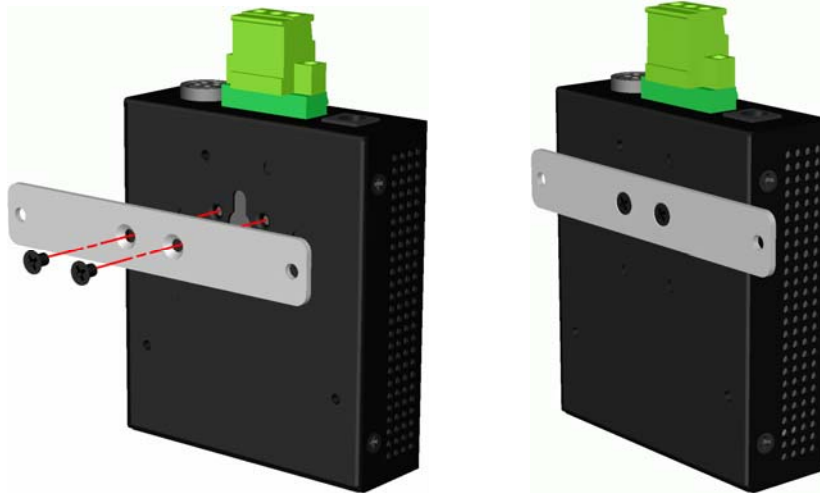

3. Screw the device on a panel and the locations for screws are shown below:



The final dimension is:

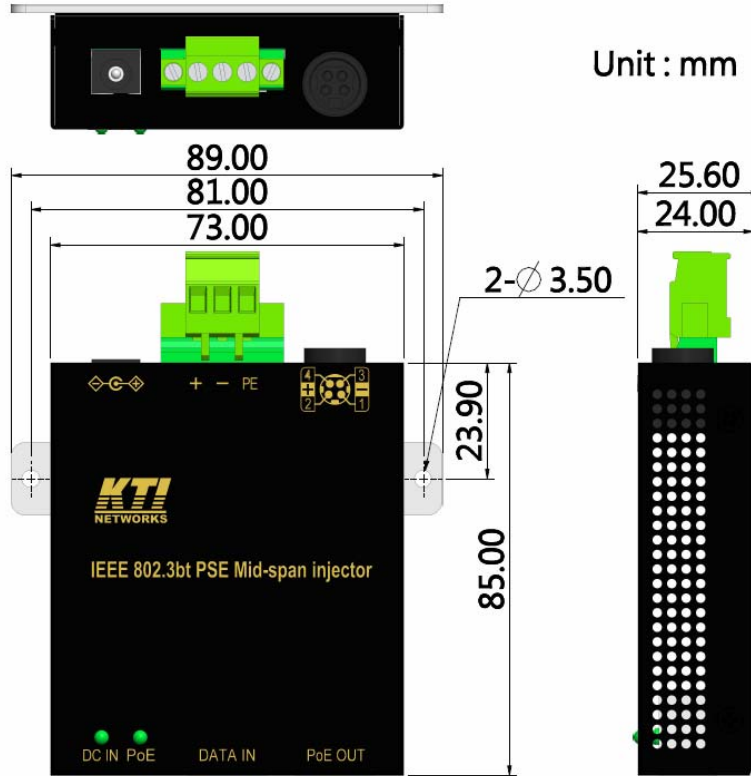

2.4 Applying DC Power

DC Power Connectors

The device is featured with three different DC power input connectors for supporting different types of external AC-DC power supply or AC-DC power adapters.

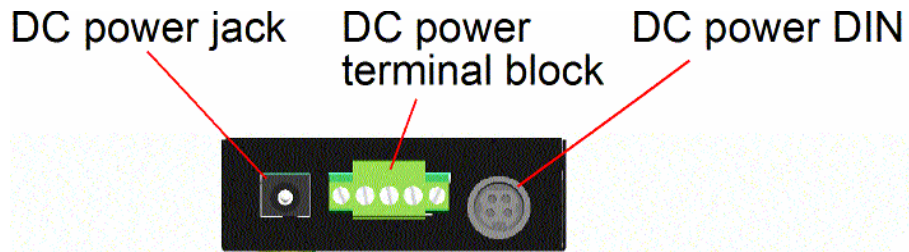

Connector	Marking	Power Supply
Terminal Block		General DC power supply with terminal contacts
DC Jack		AC-DC power adapters with DC plug
Female Power DIN		AC-DC power adapters with male power DIN

Selecting Voltage

Type	PD Class	DC power Working voltages	DC power Min. (*1)	PSE output Max.	PD input Min. (*2)
1	0	+45 ~ 57V	45V	15.4W	12.95W
1	1	+45 ~ 57V	45V	4W	3.84W
1	2	+45 ~ 57V	45V	7W	6.49W
1	3	+45 ~ 57V	45V	15.4W	12.95W
2	4	+45 ~ 57V	51V	30W	25.5W
3	5	+45 ~ 57V	55V	45W	40W
3	6	+45 ~ 57V	55V	60W	51W
4	7	+45 ~ 57V	55V	75W	62W
4	8	+45 ~ 57V	55V	90W	71W

*1: The minimum voltage to support the specified maximum PSE output.

*2: The minimum power received at the PD end in worst case with the specified maximum PSE output.

DC power input vs. PoE power output

Type	PD Class	Working V_{dc_in}	I_{poe} max.
1	0	+45 ~ 57V	0.375A
1	1	+45 ~ 57V	0.112A
1	2	+45 ~ 57V	0.208A
1	3	+45 ~ 57V	0.375A
2	4	+45 ~ 57V	0.636A
3	5	+45 ~ 57V	0.919A
3	6	+45 ~ 57V	1.35A
4	7	+45 ~ 57V	1.65A
4	8	+45 ~ 57V	2.32A

- PoE output voltage is about equal to DC IN voltage with a small voltage drop of 0.2V typically.
- PoE output current maximum can be treated as a threshold of over-current event.
- PSE output power max. \approx PoE output voltage x output current max.
- The PoE voltage measured at the PD end may be in the range of 36 ~ 57VDC.

Terminal Plug & Power Wire

A 3P flange terminal plug is provided together with the device as shown below:

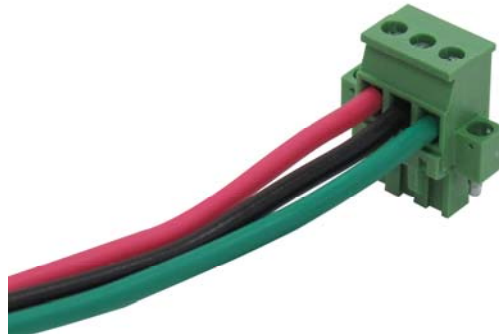

Power wires: 24 ~ 12AWG (IEC 0.5~2.5mm²)

Wire length: 1 meter max.

Pin	Marking	Power wire color	Remark
1	DC+	Red	DC power input (+), isolated to chassis ground in circuitry
2	DC-	Black	DC power input (-), isolated to chassis ground in circuitry
3	PE	Green	Protective earth, Connected to chassis ground inside, Applied if needed.

*Contacts, DC+ and DC- are isolated with PE contact.

2.4.1 Power Loss

The power voltage received at the PD end over Cat.5 is different from the voltage supplied at the device's DC power connector. The voltage drop is caused by the resistance inside the device and the Cat.5 LAN cable line resistance before the power arrives PD end. The voltage drop means power loss in the path of power delivery.

Here is some information for reference.

Device resistance	1Ω
-------------------	----

Voltage drop over standard Cat.5 (Wire: 24AWG, Length: 100m)

Current	Cable pair	Voltage drop
2A	4	2V
2A	2	8.3V
1A	4	1V
1A	2	4.1V

Note:

1. The device (PSE) delivers the power over 4 pairs for all PD classes.
2. However, some PDs might use 2 pairs only in receiving PoE power. Refer to each PD's documents for details.

3. Making LAN Connections

3.1 Data In Jack

The RJ-45 jack is used to connect a PoE-incapable Ethernet device that communicates with the remote powered device. The injector operates transparently to Ethernet port functions like auto MDI/MDI-X function and Auto-negotiation function. The network signal is forwarded to PoE OUT jack.

It supports:

Ethernet interfaces

10BASE-T, 100BASE-TX, 1000BASE-T

Network Cables

10BASE-T: 2-pair UTP Cat. 3, 4, 5, EIA/TIA-568B 100-ohm

100BASE-TX: 2-pair UTP Cat. 5, EIA/TIA-568B 100-ohm

1000BASE-T: 4-pair UTP Cat. 5 or higher (Cat.5e is recommended), EIA/TIA-568B 100-ohm

3.2 PoE OUT Jack

The RJ-45 is enabled to deliver power together with network signal to a connected powered device via Ethernet cable. To make a IEEE standard PoE connection, the connected PoE PD must be IEEE 802.3af, IEEE 802.3at, IEEE 802.3bt-compliant device for safety reason.

Network cable for PD connection

4-pair Cat.5, 5e, 6 or better

No 2-pair cable

Safety Features

The injector is equipped with the following capabilities for a safe and reliable connection:

1. Detection for an IEEE 802.3af /802.3at/802.3bt compliant PD.
2. No power is supplied to a device which is classified incompliant PD.
3. No power is supplied when no connection exists on the port.
4. The power is cut off immediately from powering condition when a disconnection occurs.
5. The power is cut off immediately from powering condition when overload occurs.
6. The power is cut off immediately from powering condition when over-current occurs.
7. The power is cut off immediately from powering condition when short circuit condition occurs.

3.3 Connection Distance

Connecting standard PD

The following figure illustrates a typical application of the device connecting to a standard PD.

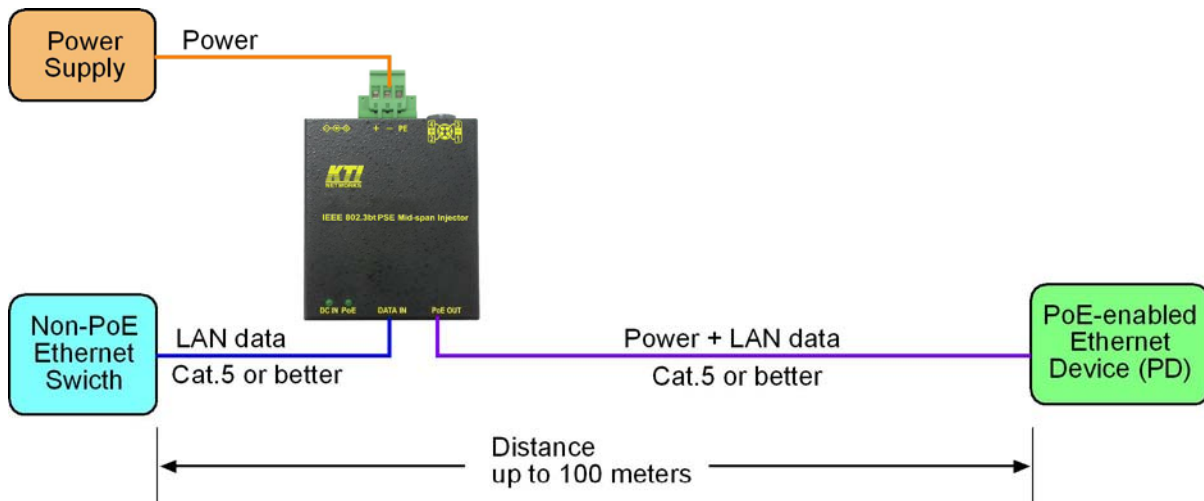

The cable distance including the segment from the injector to the Ethernet device and the segment to PD is no more than 100 meters.

Connecting PoE splitter

The figure below illustrates another example that the device connects to a PoE splitter for a non-PoE device. A PoE splitter operates as a PD that splits PoE input to pure power line and separated LAN interface.

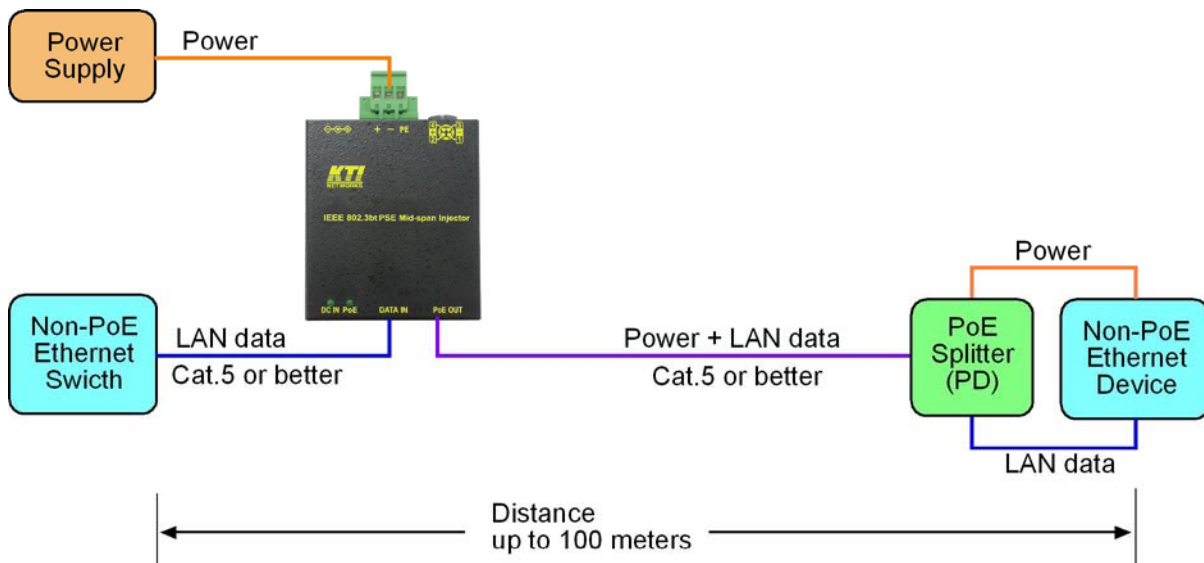

3.4 LED Indication

LED	State	Interpretation
DC IN	OFF	No power is supplied on DC power input.
	ON	DC power is supplied.
PoE	OFF	PoE output is shutdown.
	ON	PoE power is delivered.

4. Supporting Products

Power Supplies

L02-0001-089	AC-DC power adapter with 48V 90W output
KPW-300T-48	AC-DC Power supply for PoE/PoE+ with DC48V output up to 300W
KPW-300T-52	AC-DC Power supply for PoE/PoE+ with DC52V output up to 300W
KPW-300T-54	AC-DC Power supply for PoE/PoE+ with DC54V output up to 300W

PoE Splitters

KPW-T2P25-5V	IEEE 802.3at Type 2 PoE splitter with 5VDC power output up to 25W
KPW-T2P25-9V	IEEE 802.3at Type 2 PoE splitter with 9VDC power output up to 25W
KPW-T2P25-12V	IEEE 802.3at Type 2 PoE splitter with 12VDC power output up to 25W
KPW-D48T12-60	Isolated 48V-12V 60W DC-DC converter for KPW-T4SP
KPW-D48T12-90	Isolated 48V-12V 90W DC-DC converter for KPW-T4SP
KPW-D48T24-60	Isolated 48V-24V 60W DC-DC converter for KPW-T4SP
KPW-D48T24-90	Isolated 48V-24V 90W DC-DC converter for KPW-T4SP