



KCD-300



Industrial 10/100Base-TX to 100Base-FX Media Converters

Panel Mounting Bracket
KCD-3PB



The industrial KCD-300 media converter series provides industrial strength Ethernet copper-to-fiber media conversion, allowing for 10Base-T-100Base-FX or 100Base-TX-100Base-FX over multi-mode or optional single-mode fiber optical media.

Benefits:

- Comprehensive configuration settings to increase flexibility for application needs
- Wide operating temperature range for temperature critical environment
- Support DIN rail mounting and panel mounting
- Provide two power input types to meet more application needs
- Accept wide power input voltage range for application flexibility
- Industrial-rated Emission and Immunity performance

Key Features:

- Support full wire speed conversion for 10/100 speed and media types
- Support auto-negotiation 10/100Mbps or forced mode on TP copper port
- Auto MDI/MDI-X crossover function on the TP copper port
- Provide Link Fault Pass Through function
- Provide comprehensive manual configuration settings
- Transparent conversion to 802.1Q VLAN tagged packets
- Provide Far End Fault function on FX (fiber) port
- Low power consumption
- Two power interface types: screw terminal block and DC Jack
- Support wide power input voltage range
- Support DIN rail mounting and optional screwed plane mounting
- Support wide operating temperature range
- Industrial-rated Emission and Immunity performance

EMI EMS Safety Environmental Tests:

Test	Standard	Specifications
FCC/EMI	FCC Rule Part 15	Class B
CE/EMC/EMI	EN55022, CISPR 22	Class B
CE/EMC/Harmonic	EN 61000-3-2	< 75 W
CE/EMC/VFF	EN 61000-3-3	Clause 5
CE/EMC/EMS	EN 55024	
ESD Test	IEC 61000-4-2	+/-8KV
RS Test	IEC 61000-4-3	Strength: 10V/m
EFT/BURST	IEC 61000-4-4	Power: +/-4KV
Surge Immunity	IEC 61000-4-5	Data: +/-2KV
CS Test	IEC 61000-4-6	Level 3
Magnetic Field Imm.	IEC 61000-4-8	50Hz 40A/m
Voltage Dips Imm.	IEC 61000-4-11	Interruption: C Dips: A
Safety	EN 60950, IEC 60950	
Dielectric Voltage	IEEE 802.3	TP, 1500VAC/60sec.
Insulation Resistance	IEEE 802.3	TP, 500VDC/10Mohm
Cold Test	IEC 60068-2-1 Ad	-20°C, 96hrs
Dry Heat Test	IEC 60068-2-2 Bd	+70°C, 40%RH, 96hrs
Damp Heat Test	IEC 60068-2-3 Ca	+60°C, 90%RH, 96hrs
Storage Test	IEC 60068-2-48	-20°C, 96hrs +85°C, 40%RH, 96hrs
Vibration Test	IEC 60068-2-64 Fh	10-200Hz, 0.1g/Hz 200-500Hz, 0.03g/Hz

Specifications:

Conversion 10BASE-T to 100BASE-FX, 100BASE-TX to 100BASE-FX

Conversion Methods Smart-forward mode:
- Store-and-forward for 10M to 100M
- Direct conversion for 100M to 100M
Store-and-forward always mode

Packet Types Transparent conversion with no modification to:
- Standard IEEE 802.3 Ethernet packet frames
- IEEE 802.1Q tagged packet frames

TP Port Shielded RJ-45 jack
Auto MDI/MDI-X crossover function
Auto-negotiation function for speed and duplex mode
Full-duplex and Half-duplex support
10Mbps - Supports Cat.3, 4, 5 UTP cable up to 100m
100Mbps - Supports Cat.5, 5e or higher UTP cable up to 100m

Fiber (FX) Port Multimode ST, SC, Single mode SC,
100Mbps Full-duplex and Half-duplex support
MMF 50/125µm, 62.5/125µm fiber cable

Ordering Information:

Model KCD-300-xxx	FX Port Fiber	Ref. Distance	Operating Temperature
-T	ST MMF	2km	-20°C ~ 70°C
-C	SC MMF	2km	-20°C ~ 70°C
-SL2	SC SMF	20km	-20°C ~ 70°C
-SL3	SC SMF	30km	-20°C ~ 70°C
-SL4	SC SMF	40km	-20°C ~ 70°C
-SL6	SC SMF	60km	-20°C ~ 70°C
-SL8	SC SMF	80km	-20°C ~ 70°C
-SL10	SC SMF	100km	-20°C ~ 70°C
-SL12	SC SMF	120km	-20°C ~ 70°C
-W3520	Bi-Di SC SMF	20km	-20°C ~ 70°C
-W5320	Bi-Di SC SMF	20km	-20°C ~ 70°C
-W3540	Bi-Di SC SMF	40km	-20°C ~ 70°C
-W5340	Bi-Di SC SMF	40km	-20°C ~ 70°C

	SMF 9/125µm cable Far End Fault Indication support
Flow Control	IEEE 802.3x for Full-duplex, Back pressure for Half-duplex
LEDs	- Power status - TP port link, activity, speed, duplex status - Per FX port link, activity, optical link status
Configuration Setting Switches	Auto/forced mode, TP speed, TP duplex FX duplex
DC Power Input	Screwed terminator block: 2 pairs of +/- contacts DC jack: -D 6.3mm/+D 2.0mm Operating voltage range: +7 ~ +30VDC
Power Consumption	3W max. @30VDC power input
Dimension	28 x 82 x 95 mm, Weight: 250g
Housing	Enclosed metal with no fan
Mounting Support	DIN-Rail mounting, Panel mounting
Environment	Operating Temperature: See ordering information Storage Temperature: -20°C ~ 85°C Relative Humidity: 5% ~ 90% non-condensing
Approval	FCC Class B, CE mark Class B, EN 60950-1 safety

Fiber Optical Specifications:

Model	FX & Cable	Wavelength	Tx Power*	Rx Sens.	Rx Max.
-T	ST MMF	1310nm	-20 ~ -14dBm	-32dBm	-8dBm
-C	SC MMF	1310nm	-20 ~ -14dBm	-31dBm	0dBm
-SL2	SC SMF	1310nm	-15 ~ -8dBm	-30dBm	-5dBm
-SL3	SC SMF	1310nm	-15 ~ -8dBm	-34dBm	0dBm
-SL4	SC SMF	1310nm	-5 ~ 0dBm	-34dBm	0dBm
-SL6	SC SMF	1310nm	-5 ~ 0dBm	-35dBm	0dBm
-SL8	SC SMF	1310nm	0 ~ +5dBm	-36dBm	0dBm
-SL10	SC SMF	1550nm	-5 ~ 0dBm	-35dBm	-3dBm
-SL12	SC SMF	1550nm	0 ~ +5dBm	-35dBm	-3dBm
-W3520	Bi-Di SC SMF	Tx 1310nm Rx 1550nm	-14 ~ -8dBm	-31dBm	0dBm
-W5320	Bi-Di SC SMF	Tx 1550nm Rx 1310nm	-14 ~ -8dBm	-31dBm	0dBm
-W3540	Bi-Di SC SMF	Tx 1310nm Rx 1550nm	-8 ~ 0dBm	-34dBm	0dBm
-W5340	Bi-Di SC SMF	Tx 1550nm Rx 1310nm	-8 ~ 0dBm	-34dBm	0dBm

*Data for 62.5/125µm MMF, 9/125µm SMF

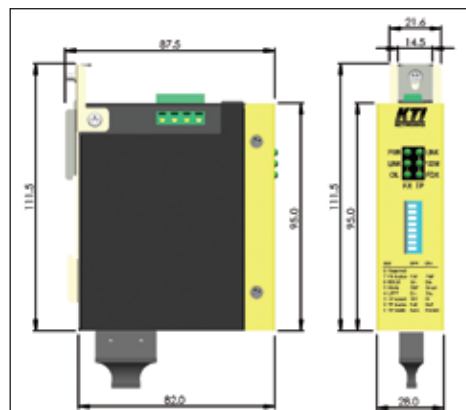

Din-Rail Mount Dimension

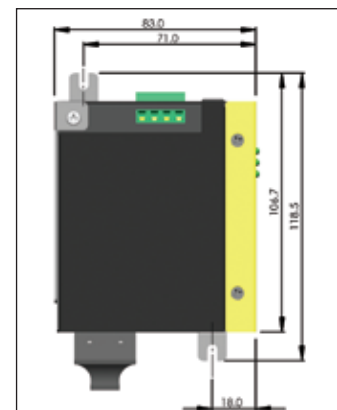

Panel & Wall Mount Dimension



Katron Technologies Inc.
15F-7, No. 79, Sec. 1, Hsin Tai Wu Rd.,
Hsi-chih District, New Taipei City, Taiwan
Tel: 886-2-2698-3878
Fax: 886-2-2698-3873
E-mail: kti@ktnet.com.tw
URL: http://www.ktnet.com.tw

Trademarks: All brand names are trademarks or registered trademarks of their respective holders.
This information is subject to change without prior notice.